



“Read and Save These Instructions”

Deionized, Demineralized, or Reverse Osmosis Water

“SXDDR” Series
Steam Heat Exchanger Humidifier

Installation Instructions

Operation and Maintenance Manual

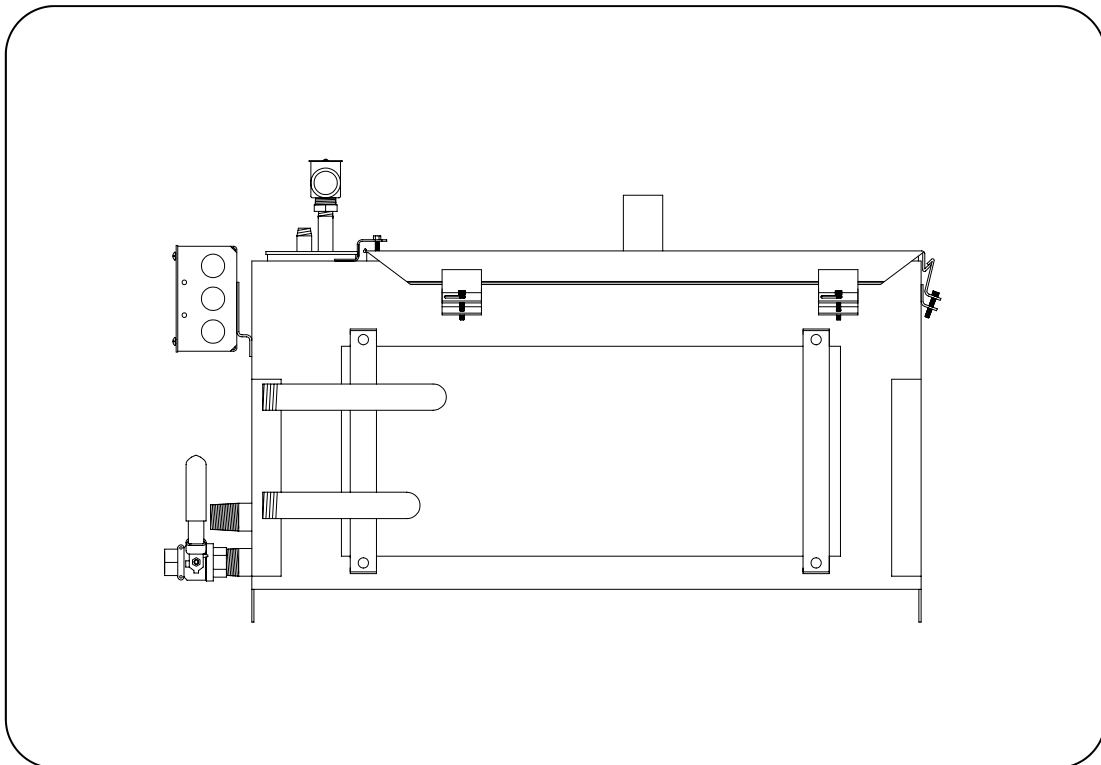

Our results are comforting

To the user of PURE Humidifier Co.'s "SXDDR" Humidifiers

We at PURE Humidifier Co. thank you for choosing one of our quality products. PURE Humidifier Co.'s "SXDDR" Series humidifiers are models of simplicity to install, operate and maintain. However, they must be maintained to provide maximum operating efficiency.

PLEASE READ AND FOLLOW ALL INSTRUCTIONS CAREFULLY. PROPER OPERATION AND HUMIDITY CONTROL IS POSSIBLE ONLY WITH PROPER INSTALLATION AND MAINTENANCE.

The "SXDDR" Series Humidifier is specifically designed to operate with deionized, demineralized, or reverse osmosis water. All components that will be in contact with the water are constructed of stainless steel, incoloy, or corrosion resistant materials.

Use of mineralized (hard or soft) tap water will cause fill valve failure and void the warranty. PURE Humidifier Co.'s "SX" Series should be installed on applications that require tap water.

High chloride content in feed water can cause chloride stress cracking and chloride pitting in stainless components. Chloride stress corrosion cracking (CSCC) and chloride pitting of stainless steel components is not covered by warranty. Do not use hydrochloric acid descalers or bleach to clean the tank. Consult the factory if you are unsure about which chemical descaler to use.

To ensure proper installation of this product, it must be installed by qualified HVAC and electrical contractors, and must be in compliance with local, state, federal, and governing codes. If installed improperly this product may cause damage to property, severe personal injury, or death as a result of electric shock, burns, and/or fire.

The PURE Humidifier Co. Warranty

PURE Humidifier Co. guarantees its products to be free from defects in material and workmanship for a period of two years from the date of shipment; provided the product is properly installed, serviced, and put into the service for which it was intended.

PURE Humidifier Co. is obligated under the terms of this warranty to the repair or replacement of the defective part(s), excluding any labor charges, or to refund the purchase price at our option. PURE Humidifier Co. assumes no obligation for incidental or consequential damages. The above provisions are in lieu of all other guarantees, obligations, liabilities or warranties, expressed or implied.

Table of Contents

Introduction	1
Internal Humidifier Features	1
Steam Supply & Condensate Piping	2
Capacities & Piping (SXDDR-1R thru SXDDR-4R)	3
Dimensions, Weights & Layout (SXDDR-1R thru SXDDR-4R)	4
Capacities & Piping (SXDDR-8R)	5
Dimensions, Weights & Layout (SXDDR-8R)	6
Capacities & Piping (SXDDR-12R)	7
Dimensions, Weights & Layout (SXDDR-12R)	8
Location & Mounting	9
Mounting Applications	10
Hose Kit Installation/Drain Tee	11
Steam Supply Piping Examples	12
Water Supply Piping	13
Pre-Startup Checklist	14
Non-INTAC® Start-Up Procedure	15
INTAC® Start-Up Procedure	16
Maintenance Instructions & Notes	17
Exchanger Gasket Replacement Instructions	18
Cover Gasket Replacement Instructions	19
Trouble Shooting	20
Tool Requirements & Torque List	21
SXDDR-1R thru SXDDR-4R Exploded Parts Drawing	22
SXDDR-1R thru SXDDR-4R Parts List	23
SXDDR-8R Exploded Parts Drawing	24
SXDDR-8R Parts List	25
SXDDR-12R Exploded Parts Drawing	26
SXDDR-12R Parts List	27

Internal Features of the PURE Humidifier Co. "SXDDR" Series Steam Heat Exchanger Humidifier

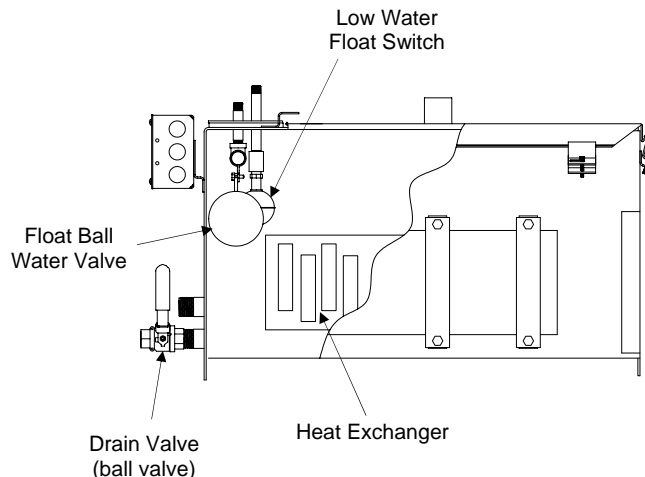

Right Side View
Side Removed for Clarity



Steam Supply & Condensate Piping

Steam Supply Piping

The "SXDDR" Series humidifier requires a steam supply source for the heat exchanger. The steam supply pressure should be at the rated pressure shown on the humidifier nameplate. **WARNING: Do not exceed the steam pressure rating shown on the humidifier nameplate. Heat exchanger failure and bodily harm may result.**

The steam supply should be taken from the top of the steam main, and the steam main should be adequately trapped to assure dry steam is delivered to the humidifier.

The strainer (provided) should be installed prior to the humidifier control valve. The steam control valve should be connected to the TOP connection of the heat exchanger. The valve must be connected to the heat exchanger with unions to allow for exchanger removal. Reference illustrations on pages 3, 5 & 7.

Condensate Piping

The SXDDR-1R thru SXDDR-4R humidifiers have one 3/4"-IPS condensate drain piping connection, the SXDDR-8R has two, and the SXDDR-12R has three. The condensate trap (provided) should be piped to the BOTTOM connection on the heat exchanger. A drip leg should be installed prior to the condensate trap. Reference illustrations on pages 3, 5 & 7.

The condensate piping should be schedule 40 black piping, stainless steel, or as specified by the project engineer.

In order for the steam trap to remove condensate, it is essential that the pressure in the condensate return line be substantially below the steam supply pressure. In the event the return line is at a higher elevation than the steam trap, a condensate collection and pump system will be required (available from PURE Humidifier).



Capacities & Piping

SXDDR-1R thru SXDDR-4R

Humidifier Capacity in pounds per hour (Kg/hr) †

Model Number	Steam Pressure in psig (Kpa) at the control valve			
	5 psig (34.5)	10 psig (69.0)	13 psig (89.6)	15 psig (103.4)
SXDDR-1R	32.0 (14.5)	76.0 (34.5)	100.0 (45.3)	122.0 (55.3)
SXDDR-2R	52.0 (23.6)	108.0 (48.9)	140.0 (63.5)	169.0 (76.7)
SXDDR-3R	102.0 (46.3)	228.0 (103.4)	292.0 (132.5)	348.0 (157.8)
SXDDR-4R	192.0 (87.1)	484.0 (219.5)	655.0 (297.1)	753.0 (341.7)

†Actual humidifier capacity may vary due to the heat loss from the humidifier reservoir. The ambient air temperature, air velocity and injection tube system will affect the rate of heat loss from the reservoir.

The capacities shown are based on a non-insulated humidifier reservoir tested in a 70°F environment.

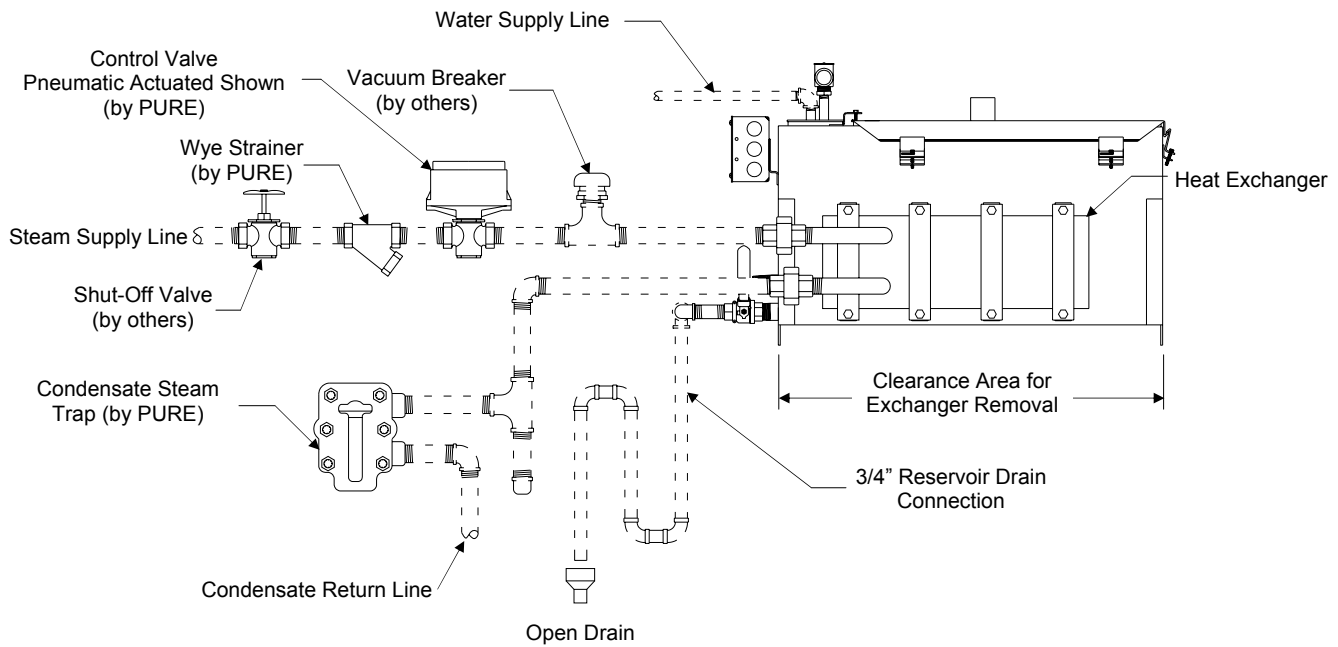

PIPING NOTES:

1. Do not install piping across the front of the heat exchanger.
2. Dashed line piping is by others.
3. Do not use PVC or plastic for any of the piping connections to the humidifier.
4. A shut-off valve must be installed in the steam supply line prior to the wye strainer (valve by others).
5. A vacuum breaker must be installed downstream of the humidifier control valve (by others).
6. Allow a minimum side clearance equal to the unit width dimension for removal of the heat exchanger (see page 4 for unit dimensions).

NEMA-12 Humidifier Control Cabinet

(reference control cabinet notes)

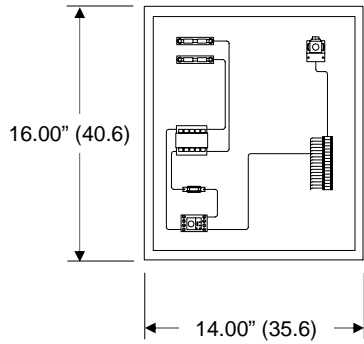

Cabinet Depth: 6.00" (15.2)

- 1) Door has been removed from the drawing for clarity
- 2) Control cabinet is shipped loose for field mounting unless optional factory mounting is specified
- 3) Control cabinet weight: 28 lbs (12.7 kg)

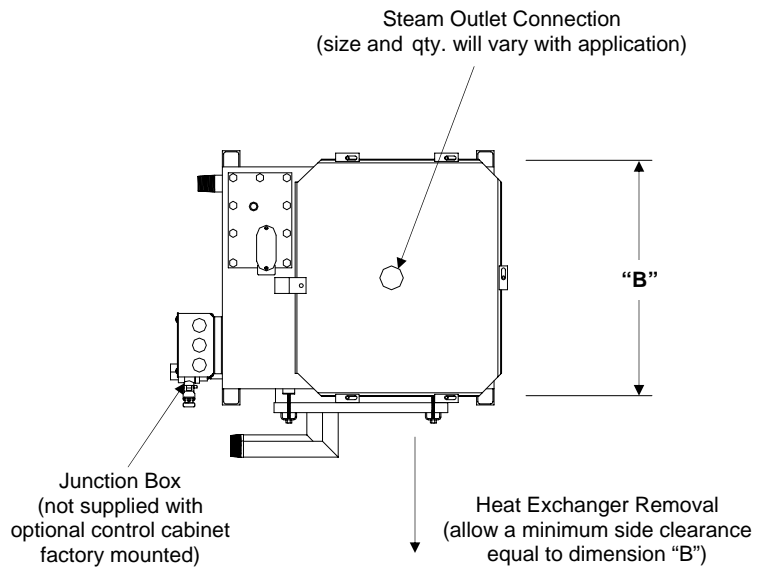

Top View

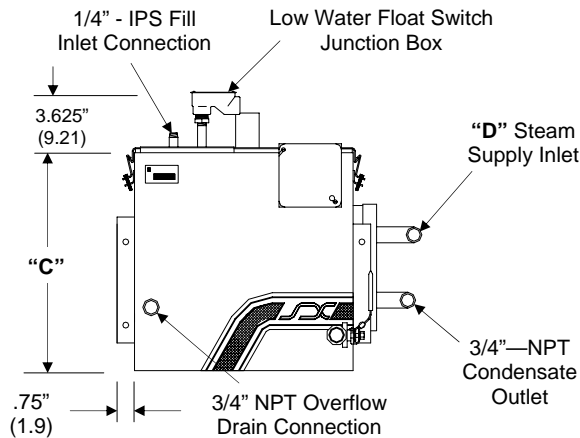

Front View

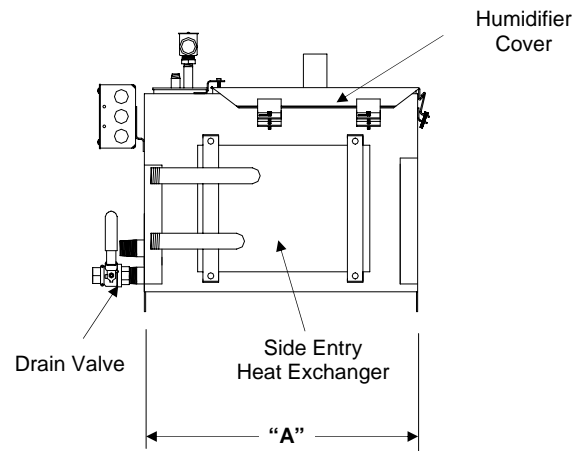

Right Side View

Unit Dimensions in Inches (cm) and Weight in Pounds (kg)*

Model Number	Dim. "A"	Dim. "B"	Dim. "C"	Dim. "D"	Shipping Weight (kg)	Operating Weight (kg)
SXDDR-1R	17.50" (44.5)	14.00" (35.6)	13.75" (34.9)	3/4" (NPT)	70 lbs (31.8)	155 lbs (70.4)
SXDDR-2R	25.50" (64.8)	14.00" (35.6)	13.75" (34.9)	3/4" (NPT)	95 lbs (43.1)	210 lbs (95.3)
SXDDR-3R	34.00" (86.4)	18.25" (46.4)	13.75" (34.9)	1-1/2" (NPT)	155 lbs (70.4)	360 lbs (163.4)
SXDDR-4R	54.00" (137.2)	27.50" (69.9)	13.75" (34.9)	2" (NPT)	285 lbs (129.4)	700 lbs (318.7)

*When calculating the total dry weight of the humidifier, the control cabinet weight must be added to the reservoir weight. Due to product improvement, catalog dimensions and specifications are subject to change without notice.

NEMA-12 Humidifier Control Cabinet

(reference control cabinet notes)

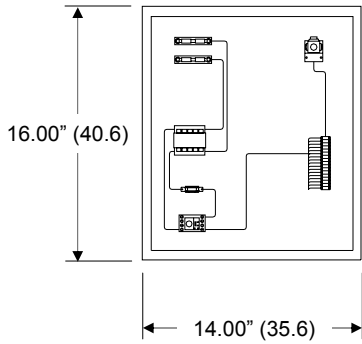

Cabinet Depth: 6.00" (15.2)

- 1) Door has been removed from the drawing for clarity
- 2) Control cabinet is shipped loose for field mounting unless optional factory mounting is specified
- 3) Control cabinet weight: 28 lbs (12.7 kg)

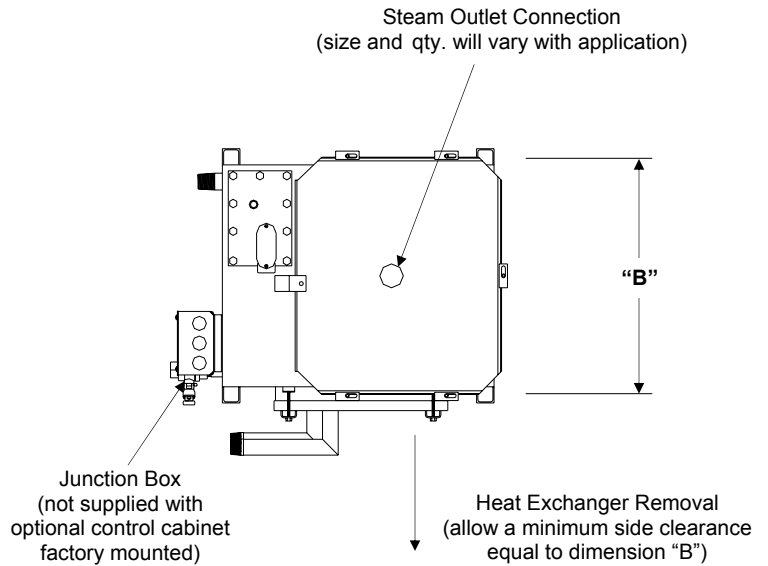

Top View

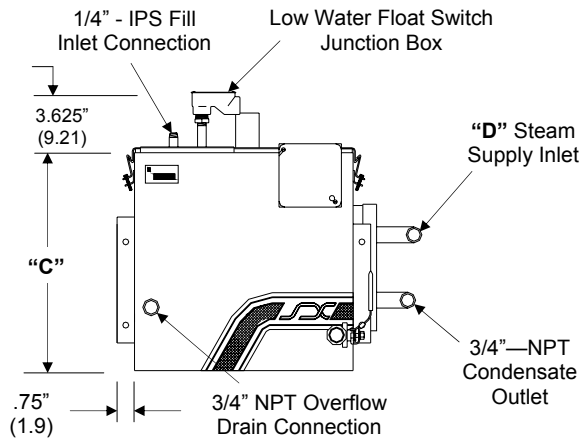

Front View

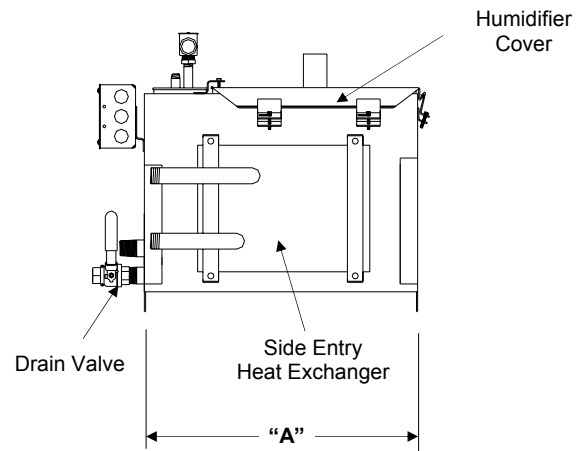

Right Side View

Unit Dimensions in Inches (cm) and Weight in Pounds (kg)*

Model Number	Dim. "A"	Dim. "B"	Dim. "C"	Dim. "D"	Shipping Weight (kg)	Operating Weight (kg)
SXDDR-1R	17.50" (44.5)	14.00" (35.6)	13.75" (34.9)	3/4" (NPT)	70 lbs (31.8)	155 lbs (70.4)
SXDDR-2R	25.50" (64.8)	14.00" (35.6)	13.75" (34.9)	3/4" (NPT)	95 lbs (43.1)	210 lbs (95.3)
SXDDR-3R	34.00" (86.4)	18.25" (46.4)	13.75" (34.9)	1-1/2" (NPT)	155 lbs (70.4)	360 lbs (163.4)
SXDDR-4R	54.00" (137.2)	27.50" (69.9)	13.75" (34.9)	2" (NPT)	285 lbs (129.4)	700 lbs (318.7)

*When calculating the total dry weight of the humidifier, the control cabinet weight must be added to the reservoir weight. Due to product improvement, catalog dimensions and specifications are subject to change without notice.

Humidifier Capacity in Pounds per Hour (kg/hr)†

Model Number	Steam Pressure in psig (Kpa) at the valve			
	5 psig (34.5)	10 psig (69.0)	13 psig (89.6)	15 psig (103.4)
SXDDR-8R	370 (167.8)	840 (381.0)	1200 (544.3)	1350 (612.4)

† Actual humidifier capacity may vary due to the heat loss from the humidifier reservoir. The ambient air temperature, air velocity, and injection tube system will affect the rate of heat loss from the reservoir.

The capacities shown are based on a non-insulated humidifier reservoir tested in a 70°F environment.

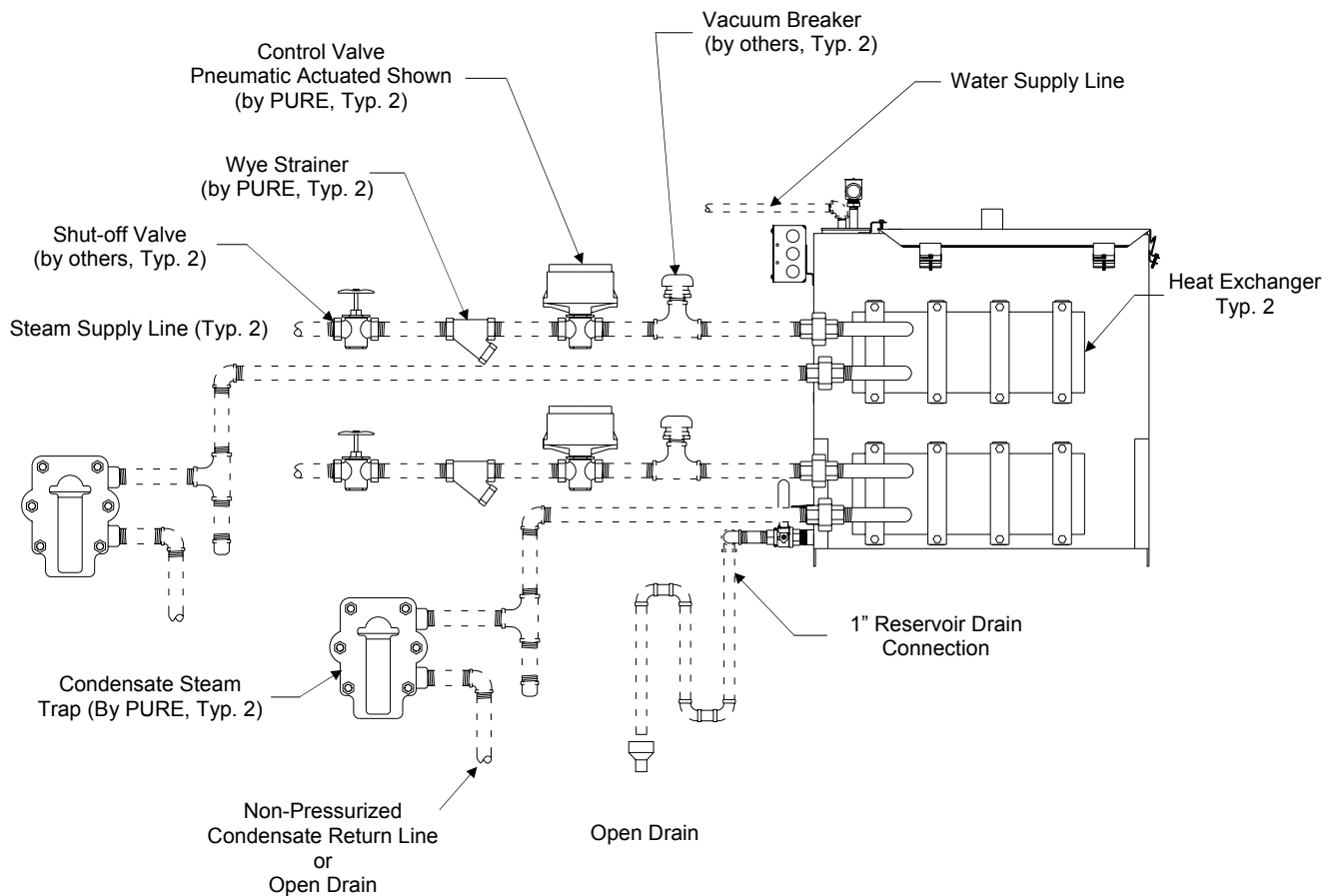

PIPING NOTES:

1. Do not install piping across the front of the heat exchanger.
2. Dashed line piping is by others.
3. Do not use PVC or plastic piping for any of the piping connections to the humidifier.
4. A shut-off valve must be installed in the steam supply line prior to the wye strainer (valve by others).
5. Allow a minimum side clearance equal to the unit width dimension for removal of the heat exchanger (see page 6 for unit dimensions).



Dimensions, Weights & Layout

SXDDR-8R

NEMA-12 Humidifier Control Cabinet (reference control cabinet notes)

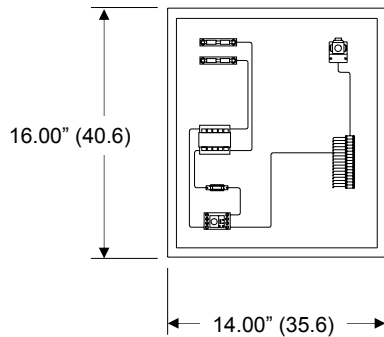

Cabinet Depth: 6.00" (15.2)

- 1) Door has been removed from the drawing for clarity
- 2) Control cabinet is shipped loose for field mounting unless optional factory mounting is specified
- 3) Control cabinet weight: 28 lbs (12.7 kg)

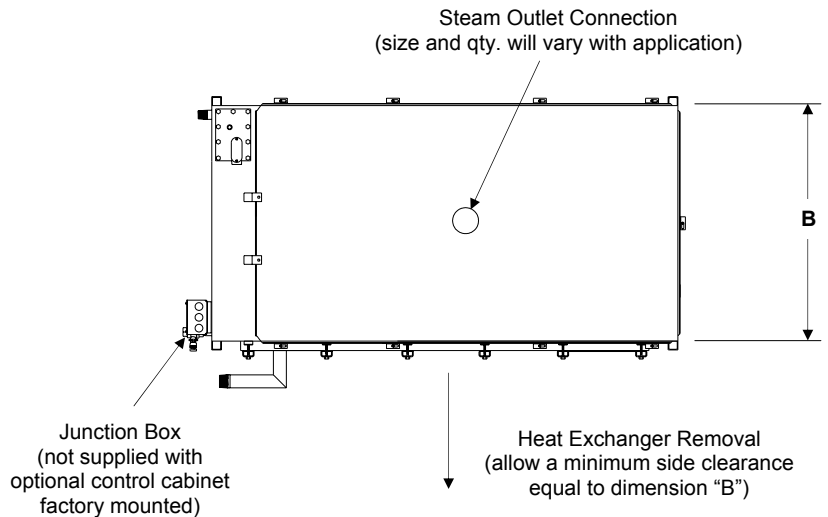

Top View

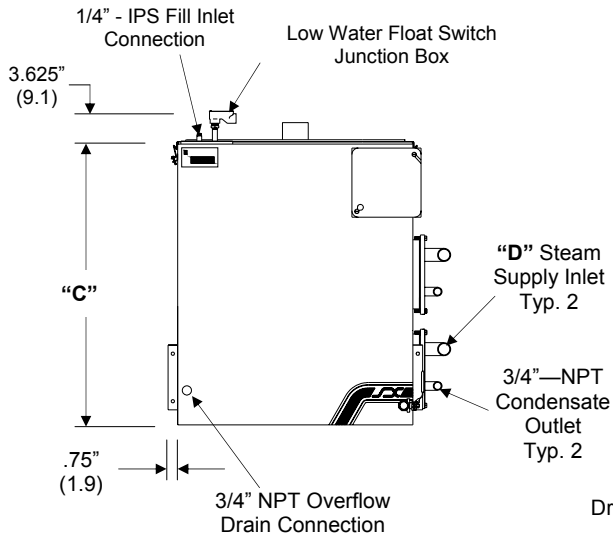

Front View

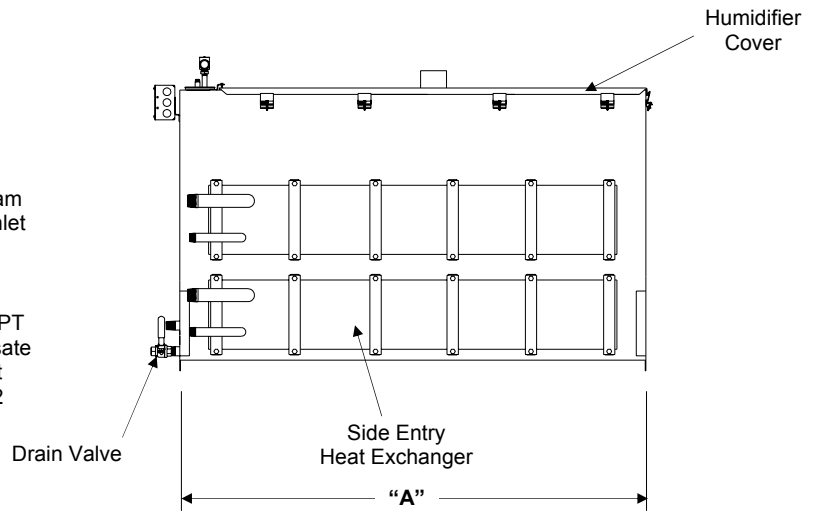

Right Side View

Unit Dimensions in Inches (cm) and Weight in lbs (kg)*

Model Number	Dim. "A"	Dim. "B"	Dim. "C"	Dim. "D"	Shipping Weight (kg)	Operating Weight (kg)
SXDDR-8R	54" (137.2)	27.25" (69.2)	32.5" (82.6)	2" (NPT)	697 lbs (316.2)	1480 lbs (671.3)

*When calculating the total dry weight of the humidifier, the control cabinet weight must be added to the reservoir weight.

Humidifier Capacity in Pounds per Hour (kg/hr)†

Model Number	Steam Pressure in psig (Kpa) at the control valve			
	5 psig (34.5)	10 psig (69.0)	13 psig (89.6)	15 psig (103.4)
SXDDR-12R	560 (254.0)	1265 (573.8)	1810 (821.0)	2035 (923.1)

† Actual humidifier capacity may vary due to the heat loss from the humidifier reservoir. The ambient air temperature, air velocity, and injection tube system will affect the rate of heat loss from the reservoir.

The capacities shown are based on a non-insulated humidifier reservoir tested in a 70°F environment.

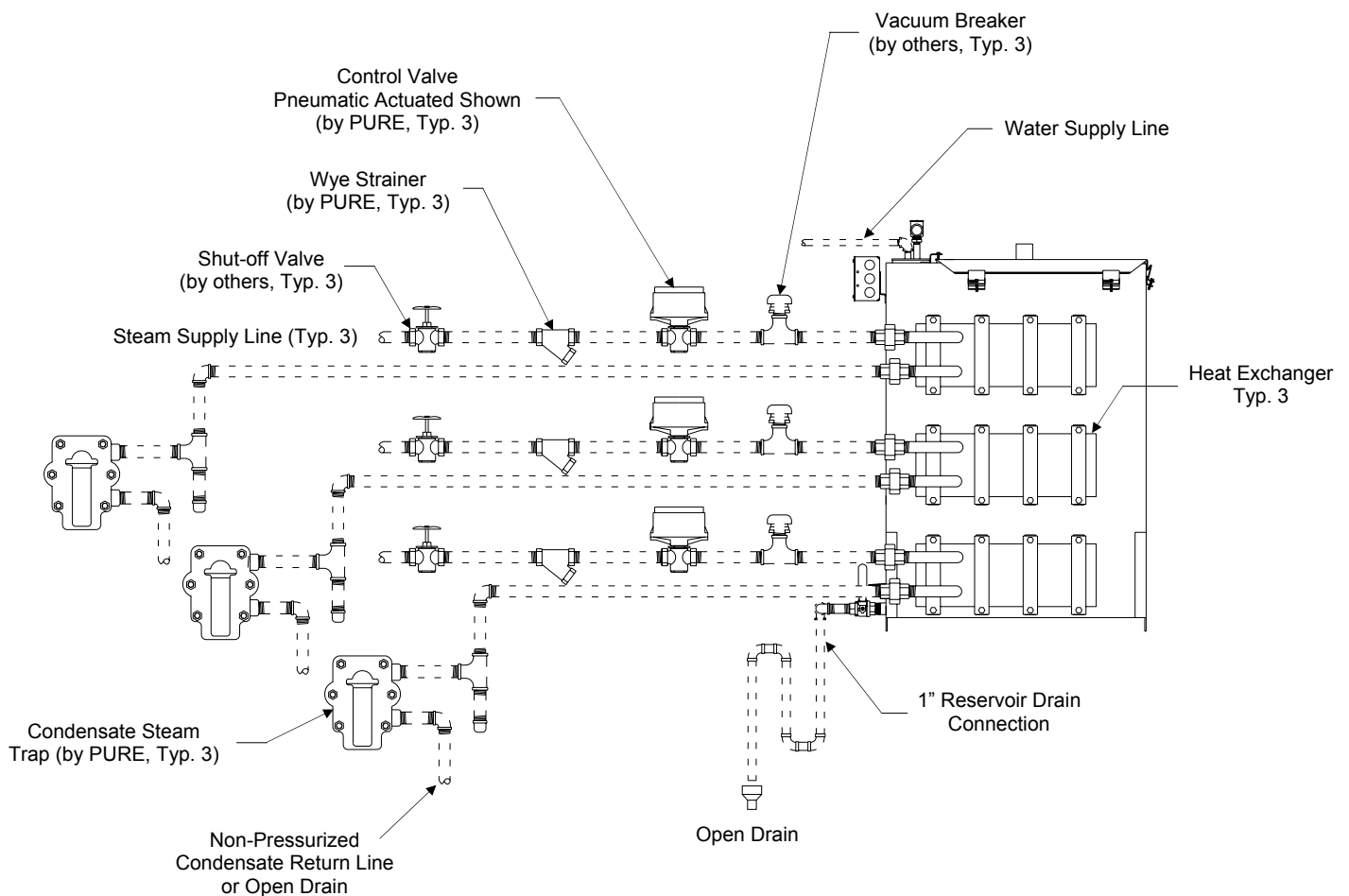

PIPING NOTES:

1. Do not install piping across the front of the heat exchanger.
2. Dashed line piping is by others.
3. Do not use PVC or plastic piping for any of the piping connections to the humidifier.
4. A shut-off valve must be installed in the steam supply line prior to the wye strainer (valve by others).
5. Allow a minimum side clearance equal to the unit width dimension for removal of the heat exchanger (see page 8 for unit dimensions).



Dimensions, Weights & Layout

SXDDR-12R

NEMA-12 Humidifier Control Cabinet

(reference control cabinet notes)

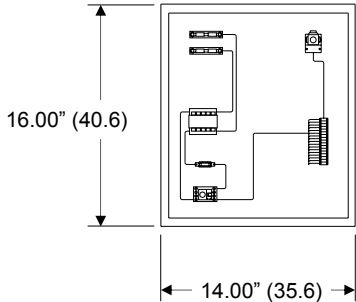

Cabinet Depth: 6.00" (15.2)

- 1) Door has been removed from the drawing for clarity
- 2) Control cabinet is shipped loose for field mounting unless optional factory mounting is specified
- 3) Control cabinet

Steam Outlet Connection
(size and qty. will vary with application)

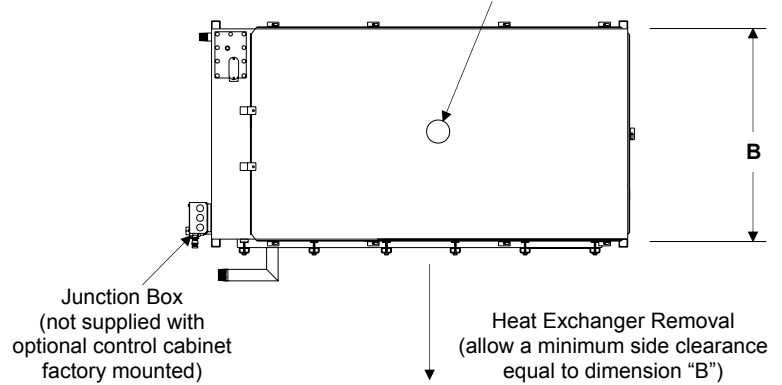

Top View

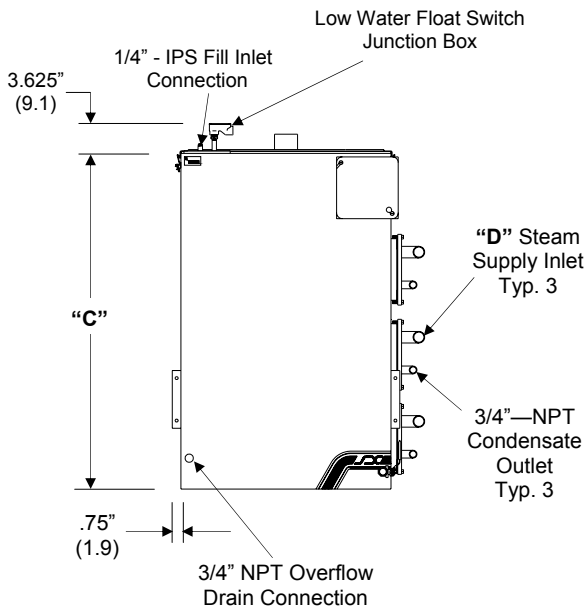

Front View

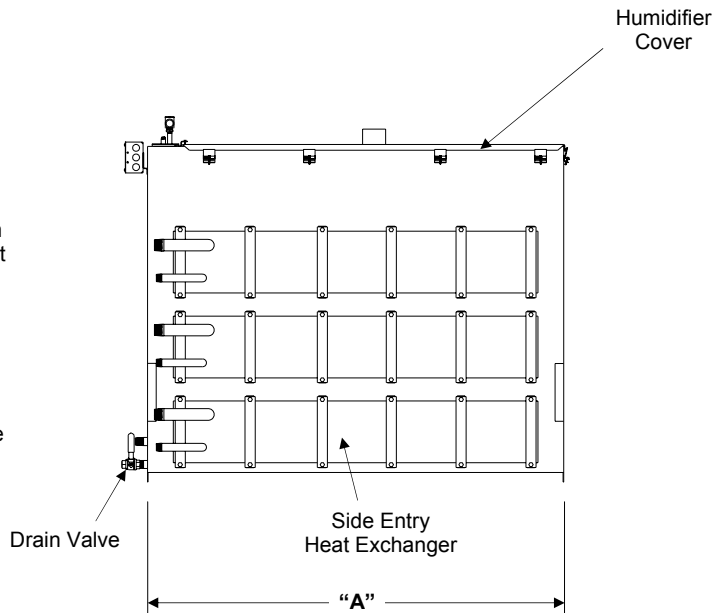

Right Side View

Unit Dimensions in Inches (cm) and Weight in Pounds (kg)*

Model Number	Dim. "A"	Dim. "B"	Dim. "C"	Dim. "D"	Shipping Weight (kg)	Operating Weight (kg)
SXDDR-12R	54" (137.2)	27.25" (69.2)	43.5" (110.5)	2" (NPT)	845 lbs (383.3)	1628 lbs (738.4)

*When calculating the total dry weight of the humidifier, the control cabinet weight must be added to the reservoir weight. Due to product improvement, catalog dimensions and specifications are subject to change without notice.



Location & Mounting

Location

The location selected must provide for electrical service, cold or hot water supply, and sanitary drain.

When selecting a location, try to keep the humidifier within 10 feet (305 cm) of the duct to avoid unnecessary heat losses, condensation and excessive back pressure within the steam supply line.

Visible “fog” will saturate and condense when it contacts objects such as turning vanes, filters, fans, elbows or take-offs. The warmer the air, the more easily it will dissipate the visible steam. The most active and warmest portion of the duct will provide better mixing of the steam and air. The injection tube should be mounted a minimum of 2 feet (61 cm) downstream from an elbow or other turbulent air flow area.

Avoid mounting the injection tube closer than 8-10 feet (244-305 cm) upstream of objects that could become saturated and condense the steam (reference the paragraph above). If the duct layout does not provide a straight unobstructed run of 8-10 feet (244-305 cm), a multiple injection tube system should be considered to reduce the visible steam travel distance.

CAUTION: Do not humidify upstream of filters. Consult factory.

Location of Controls

It is important to avoid mounting any controls within the visible steam. The controls should be mounted a minimum of 8-10 feet (244-305 cm) downstream from the humidifier injection tube. Due to the temperature rise that exists within the visible steam dissipation area, thermostats should not be mounted near the injection tube. High-limit humidistats should be installed before any duct obstruction to make sure the humidifier is interrupted before saturation can occur on the object. The high-limit should be mounted a minimum of 8-10 feet (244-305 cm) downstream from the injection tube.

Mounting

The humidifier should be mounted dead level in both directions. PURE Humidifier Co. recommends that the humidifier be mounted using one of the following two methods: (ref. page 10).

1. Mounted on the wall. PURE Humidifier Co. offers wall mounting brackets as an option. The wall bracket installation sheet should be followed when installing the brackets. *Not recommended for SXDDR-4R, 8R, or 12R humidifiers.*
2. Mounted off the floor with floor legs. PURE Humidifier Co. offers floor support legs as an option. The humidifier is mounted 24” (61 cm) up from the floor. Simple floor legs can be constructed from 1-1/4” x 1-1/4” x 1/4” angle iron. The support legs should be secured to the humidifier side mounting holes.

Drain Pan Mounting

A drain pan is an additional safety feature which may be required to be supplied in the field. In a proper humidifier installation, a drain pan is not required. However, if the humidifier and injection tube are located in or above an area that contains valuable equipment or is a water sensitive area, PURE Humidifier Co. recommends the addition of a drain pan under the humidifier and under the injection tube. The drain pan should extend past all edges of the humidifier and if installed in the duct, it should extend a minimum of 3 feet (91 cm) downstream from the injection tube. The pan should be of a size which is sufficient to retain sudden drainage of the humidifier’s contents. The pan should be drained to a sanitary drain.

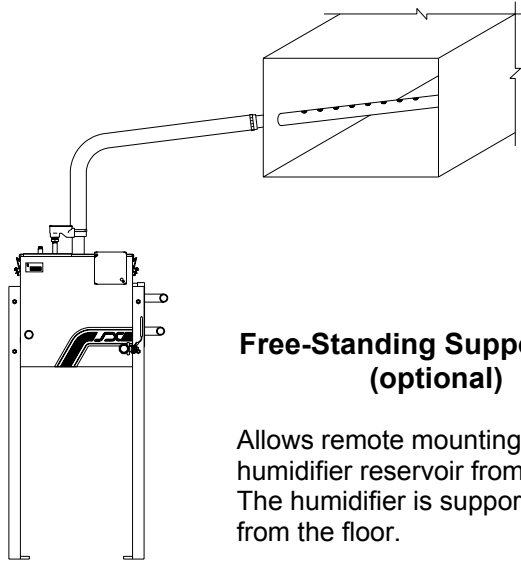

Free-Standing Support Legs (optional)

Allows remote mounting of the humidifier reservoir from the duct. The humidifier is supported 24" from the floor.

The "SXDDR" Series Humidifier offers a wide variety of mounting applications. If the duct is remote from the humidifier reservoir, free-standing floor support legs or wall brackets (both optional) are available. The humidifier can even be mounted directly within an air handling unit (local codes may require moisture proof construction of certain components). Single or multiple injection tubes can be used to custom-fit any duct or air handler size.

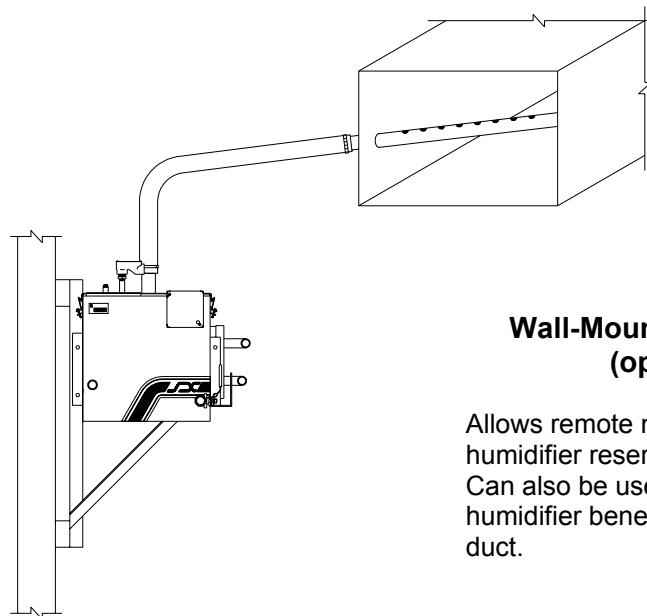

Wall-Mounting Brackets (optional)

Allows remote mounting of the humidifier reservoir from the duct. Can also be used to mount the humidifier beneath a wall mounted duct.

Flexible Hose Kit Installation

Single-tube hose kits should have the injection tube installed in the center of the duct. Multiple-tube hose kits should have the tubes staggered within the duct as shown in the illustration.

The hose and injection tube should be pitched back to the humidifier two inches (5 cm) per foot (31 cm). If proper pitch cannot be maintained, or the injection tube is mounted lower than the humidifier, a drain "tee" will be required (reference drain "tee" illustration).

Install the tube with the steam ports injecting steam up. **NOTE:** If narrow ducts (6" / 15 cm or less, in height) are utilized, install the tube with the steam ports injecting into the air flow.

The hose connects to the injection tube and humidifier with stainless steel hose clamps (by PURE Humidifier Co.).

Galvanized steel duct plates are provided to seal the opening where the tube enters the duct.

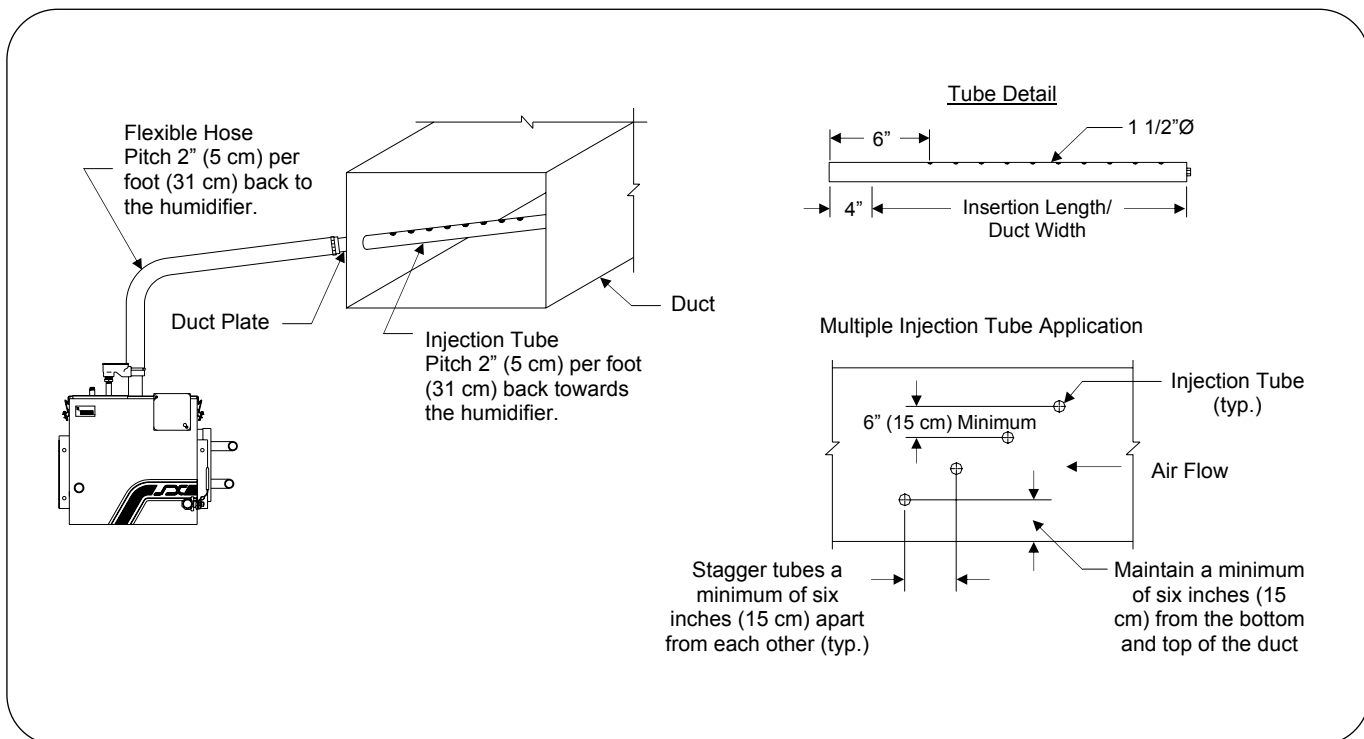
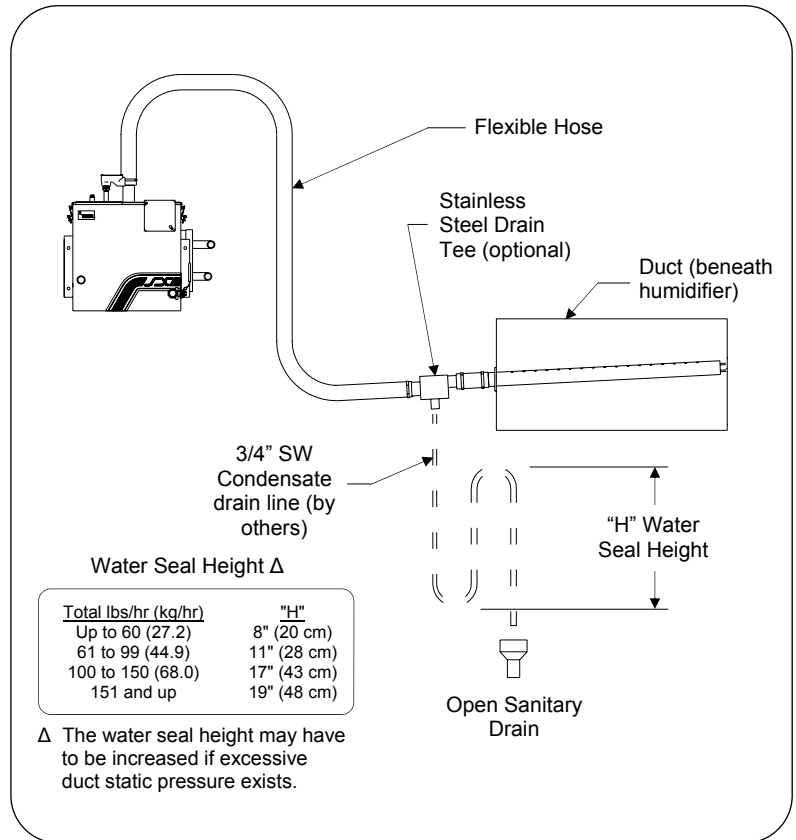

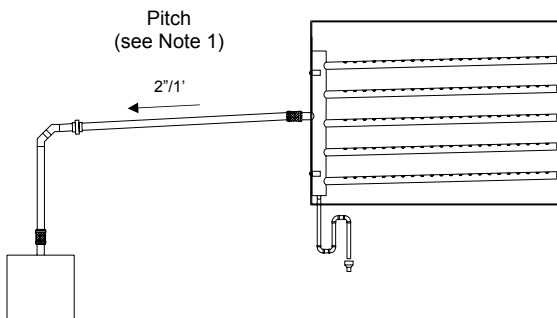

Pitched Towards Steam Generator

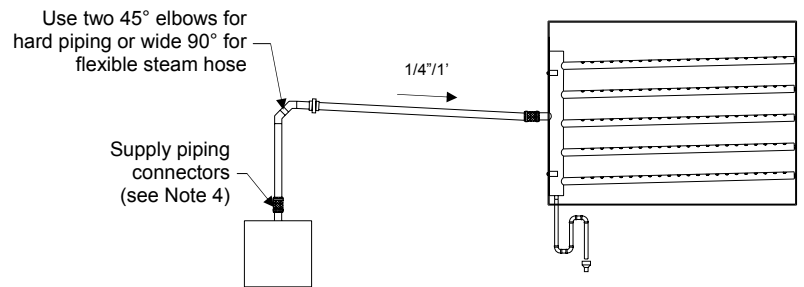

Pitched Towards Tube Assembly

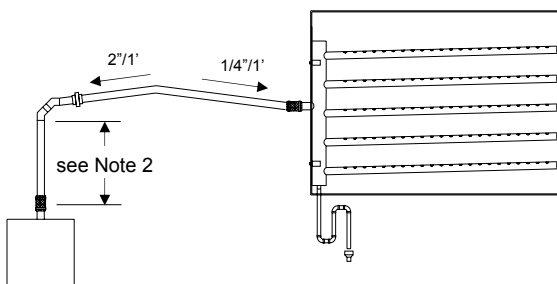

Pitched Towards Steam Generator and Tube Assembly

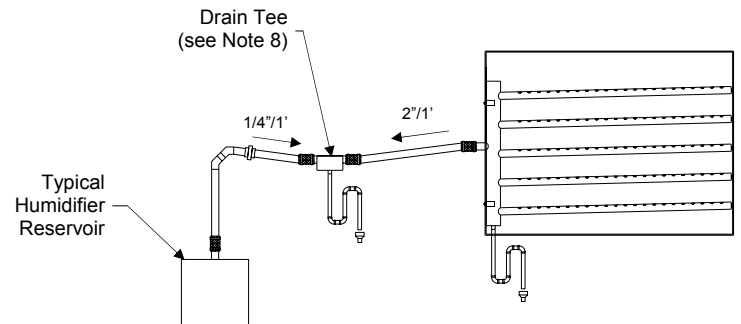

Pitched Towards Drain Tee

Notes:

1. Pitch hard piping or flexible hose 2" per foot if steam is flowing uphill, 1/4" per foot if the steam is flowing downhill. Reference piping examples shown.
2. When feasible to do so, install a minimum one-foot riser from the top of the tank to reduce condensate carry over.
3. Use flex connectors or unions to allow for easy removal of cover.
4. Support flexible hose every 18" to avoid sagging.
5. Hard piping or flexible hose must match reservoir outlet size. Do not use supply piping with a smaller inside diameter than the reservoir outlet.
6. Failure to follow the piping recommendation on this page may result in blown water seals, leaking cover gasket or dispersion tubes spitting.
7. Install a Drain Tee at any low spots in supply piping run where condensate will accumulate.
8. Reference job specific tube assembly O&M included with your order for complete details.

Water Supply Piping

Supply pressure: 15-50 psi

This style humidifier utilizes a float operated fill valve system which is designed for use with deionized, demineralized, or reverse osmosis water. Use of mineralized tap water will cause fill valve failure and will void the warranty.

Install stainless pipe on make-up water line within 5 ft of humidifier fill valve connection. If plastic pipe is used beyond this point a check valve is required to prevent steam from entering the plastic section in the event that the water treatment system runs out of water.

Cold or hot deionized, demineralized, or reverse osmosis water can be supplied to the humidifier. A minimum water pressure of 15 psi (1.03 Bar) should be maintained to provide the proper water level within the humidifier. If the water pressure is above 50 psi (3.5 Bar), the valve may not shut off or water hammer could occur and a pressure reducing valve or shock arrester should be used. The humidifier has a factory built-in 1.5" (4 cm) air gap between the water inlet and the overflow. Local codes should be checked to see if the addition of the vacuum breaking device is required.

Drain Piping

The "SXDDR" style humidifier requires two drain piping connections; a drain and an overflow connection. The two drain lines should be piped together before the water seal (as shown in the drain piping illustration).

A water seal (as shown in the piping illustration) should be installed to prevent steam from escaping through the drain line. The water seal should be of sufficient height to overcome the pressure developed in the humidifier (reference water seal height table) and the duct static pressure.

The drain piping should be stainless steel. The use of PVC piping is not recommended; the humidifier temperature may cause the PVC to soften and fail.

If gravity drain is not possible please use a condensate pump rated for 212°F water or PURE Humidifier Co. Part No. 16033 Hartell A3X-115 condensate pump.

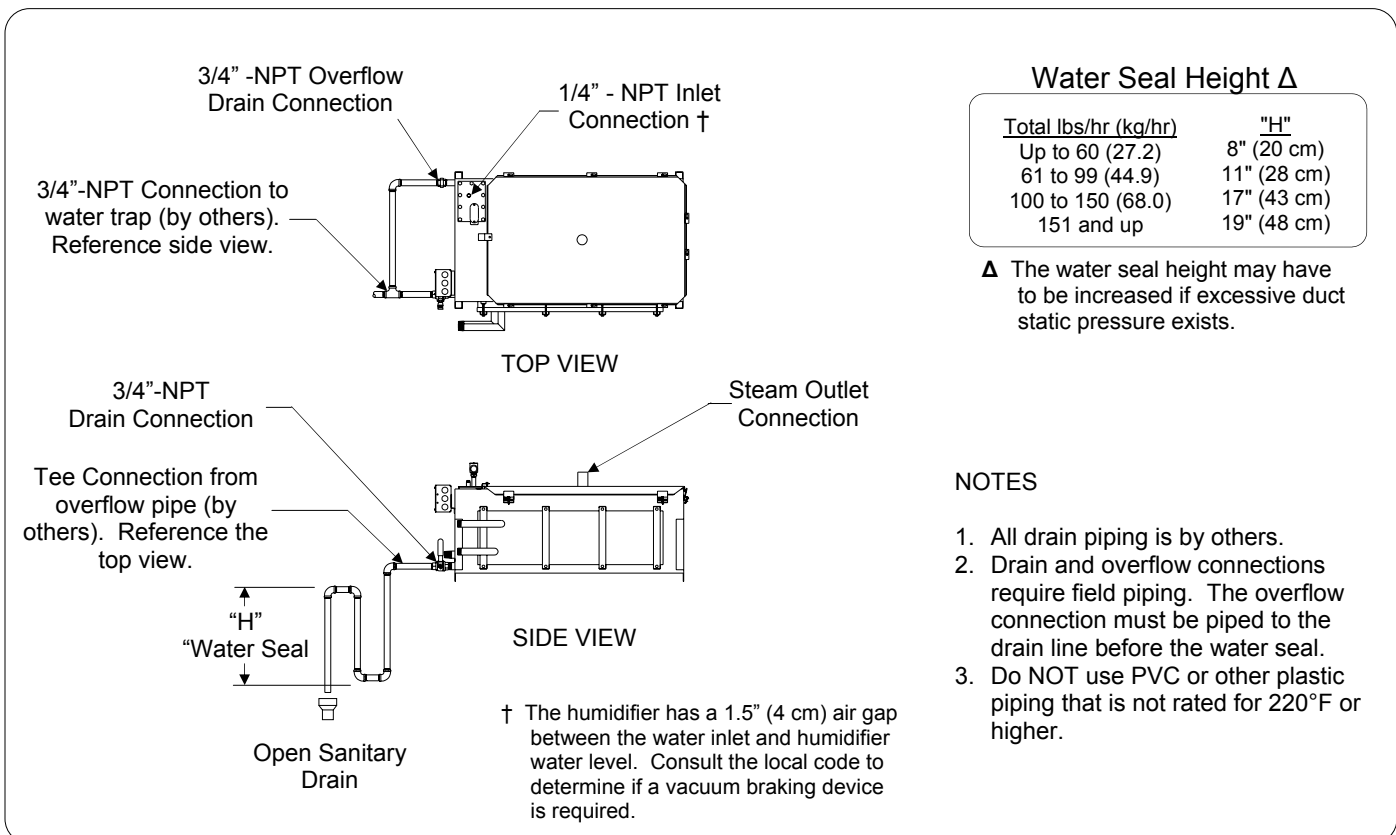



Pre-Startup Checklist

Pre-Startup Checklist

Before starting the "SXDDR" PURE Humidifier Co. Steam Heat Exchanger Humidifier, check the following installation items:

_____ 1. MOUNTING - Verify that the humidifier evaporating chamber is securely supported and that the evaporating chamber is level in both directions. If humidifier is installed above equipment or not located near a floor drain, a drain pan should be installed below the humidifier steam generator.

_____ 2. INJECTION TUBE - Verify that the humidifier injection tube is mounted within the duct with the proper pitch back to the humidifier (2"/5 cm per foot / 31 cm). NOTE: If the humidifier evaporating chamber or the flexible hose (optional) is mounted higher than the injection tube, a drain "tee" is required to drain the condensate out of the injection tube steam line. If it is an Insty-Pac or Fast Pac refer to the respective O&M to determine if they are mounted properly and have the proper p-trap size.

_____ 3. ELECTRICAL - Verify that all wiring connections have been connected in accordance with the wiring diagram. **CAUTION: Live power may exist in the control cabinet. Turn off the main power at the disconnect switch before verifying the electrical connections!**

_____ 4. SAFETY CONTROLS – The supply air duct RH high-limit should be installed at least ten feet downstream from the humidifier tube(s). Any other control sensors should be at least ten feet downstream from the humidifier tube(s). Smoke detectors should not be installed downstream of the humidifier tube(s). If a smoke detector absolutely has to be installed downstream from the humidifier tubes than it should be installed as far from the tubes as possible.

_____ 5. PIPING: Water Supply - Verify that all piping connections have been completed as recommended and that water pressure is available to the humidifier. Verify that the supply water pressure is 35-50 psi. There should be at least 5 feet of metal pipe and check valve between the tank and any plastic pipe.

_____ 6. PIPING: Drain - Make sure a water seal of the proper height (refer to steam generator O&M for height) is provided in the drain line.

_____ 7. PIPING: High-Pressure Steam Inlet - Make sure a shut-off is installed before the strainer. Make sure a strainer is installed before control valve(s). Make sure vacuum breaker(s) and union(s) is/are installed between the control valve(s) and heat exchanger(s).

_____ 8. PIPING: High-Pressure Steam Condensate Line - The condensate line should not be elevated but should run to a non-pressurized condensate pump receiver or through a drain cooler to an open drain.

_____ 9. PIPING: Steam Outlet - Refer to attachment for proper outlet steam piping from the generator to the tube(s). **Any horizontal to vertical transition in the outlet steam pipe requires a water sealed drip leg!** Improper outlet steam piping will cause steam to leak from the steam generator. Runs over 20 feet long may require upsizing of the steam pipe.

Signature: _____ Date: _____



Non-INTAC[®] Start-Up Procedure

Start-Up Procedure

- _____ 1. Make sure the electric power to the humidifier is shut off .
- _____ 2. Close the humidifier manual ball valve (located on the left side of the humidifier evaporating chamber faceplate).
- _____ 3. Open the water supply on/off control valve and allow the humidifier evaporating chamber to fill to the proper level.
- _____ 4. After the humidifier is full of water, turn on the main power to the control cabinet.
- _____ 5. Verify the low water safety switch by closing the water supply, opening the drain valve and verifying that the low voltage pilot relay within the control cabinet de-energizes when the water level is dropped below the low water shut off switch (you can hear the relay switch “out”).
- _____ 6. Close the drain valve, open the water supply valve, and allow the humidifier to fill to the proper level. Allow the tank to fill completely and make sure that the make-up water float valve shuts off completely and does not over flow the tank before proceeding.
- _____ 7. Make sure all the optional safety switches are satisfied (air-flow proving switch, high-limit humidistat, etc.).
- _____ 8. Turn the humidistat up to a “call” for humidity. The modulating steam control valve actuator should begin to open the valve and allow steam to enter the heat exchanger. NOTE: the valve actuator can be either pneumatic or electric modulating.
- _____ 9. Condensate should begin passing through the steam trap.
- _____ 10. Check operation of optional field-installed safety switches (air-flow proving switch, high-limit humidistat, etc.) to make sure that they turn the power off to the low voltage pilot relay. The safety switches should shut off the humidifier steam control valve whenever one or more of the optional safety switches create an open circuit.
- _____ 11. Check the main incoming supply steam pressure. The pressure should match the factory nameplate. A higher steam pressure than the design will cause the steam generator to leak and may damage the heat exchanger. NOTE: Do not exceed the factory nameplate pressure rating! See warning label on the humidifier.
- _____ 12. Inspect installation for leaks by operating humidifier at a full rolling boil. This may take up to 15 minutes from a cold start. Any leaks should be sealed. Just tightening a pressure clamp will not work if the gasket is not properly positioned between the sealing surfaces. If necessary remove the cover or side-entry plate, reseal gasket and replace cover or side entry plate. A small amount of adhesive (super glue, gorilla glue, spray adhesive, etc.) to hold the gasket in place while repositioning the cover or side-entry plate will aid in this process. Check hose clamp connection after unit has warmed up and make sure they are torqued to 35-40 in-lbs.

Signature: _____ Date: _____



INTAC® Start-Up Procedure

Start-Up Procedure

- _____ 1. Make sure the electric power to the humidifier is shut off .
- _____ 2. Close the humidifier manual ball valve (located on the left side of the humidifier evaporating chamber faceplate).
- _____ 3. Turn the electric power “on” to the humidifier. The display on the INTAC® controller should illuminate “Normal Operation”.
- _____ 4. Set menu 101 “RH Setpoint” to the lowest setting (no call for humidity). If 100 menu shows “No Parameters Available” the procedure must be done through the Building Management System.
- _____ 5. Open the water supply on/off control valve by others and allow the humidifier evaporating chamber to fill to the proper level.
- _____ 6. After the humidifier is full of water, menu 004 will read “FULL”.
- _____ 7. Verify the low water safety switch by closing the water supply, opening the drain valve and verifying that the low voltage pilot relay within the control cabinet de-energizes when the water level is dropped below the low water shut off switch (you can hear the relay switch “out”). Menu 004 should now read “LOW”; this indicates that the low water safety circuit is operational.
- _____ 8. Close the drain valve, open the water supply valve, and allow the humidifier to fill to the proper level.
- _____ 9. Make sure all the optional safety switches are satisfied (air-flow proving switch, high-limit humidistat, etc.).
- _____ 10. Turn menu 101 “RH Setpoint” up to a call for humidity or set the Building Management demand to 100%.
- _____ 11. Condensate should begin passing through the condensate trap.
- _____ 12. Check operation of optional field-installed safety switches (air-flow proving switch, high-limit humidistat, etc.) to make sure that they turn the power off to the low voltage pilot relay. The safety switches should shut off the humidifier steam control valve whenever one or more of the optional safety switches create an open circuit
- _____ 13. Check the main steam supply pressure. The pressure should match the factory nameplate. NOTE: Do not exceed the factory nameplate pressure rating! See warning label on the humidifier.
- _____ 14. Inspect installation for leaks by operating humidifier at a full rolling boil. This may take up to 15 minutes from a cold start. Any leaks should be sealed. Just tightening a pressure clamp will not work if the gasket is not properly positioned between the sealing surfaces. If necessary remove the cover or side-entry plate, reseal gasket and replace cover or side entry plate. A small amount of adhesive (super glue, gorilla glue, spray adhesive, etc.) to hold the gasket in place while repositioning the cover or side-entry plate will aid in this process. Check hose clamp connection after unit has warmed up and make sure they are torqued to 35-40 in-lbs.

Signature: _____ Date: _____



Maintenance Instructions & Notes

PURE Humidifier Co. “SXDDR” Maintenance Instructions

The “SXDDR” Series Humidifier is designed to provide the best possible operation with minimum maintenance. However, the humidifier should be inspected and placed on a dedicated maintenance schedule to ensure continued operation of the humidifier and its accessories. **PURE Humidifier Co. recommends that the following items be inspected and/or cleaned on a minimum basis of twice a year.** If excessive mineral build-up occurs, the maintenance schedule should be increased.

<u>Inspect/Maintenance Item</u>	<u>Procedure to Follow</u>
Water Make-Up Float Valve	Check to make sure the float valve is operating properly. If the valve appears to continually fill, check the valve adjustment or valve seat and seal (see trouble shooting instructions).
Low Water Float Switch	Check to make sure the switch will shut the humidifier off when the water level drops too low. Close the water supply and open the drain valve to allow water to drain out for checking purposes. Make sure to reset the drain valve after inspection is completed.
Safety Interlocks (air flow, high-limit)	Check to make sure the safety interlocks (air flow, high-limit, etc.) will shut down the humidifier.
Heat Exchanger	Clean and inspect for any leaks. Completely remove all mineral build-up on the heat exchanger, transfer tubes, and headers.
Steam Trap & Strainer	Clean and inspect for proper operation.
Humidifier Cover/Tank	Inspect for any leaks. Repair as required. Remove the heat exchanger and remove mineral deposits from the floor of the humidifier reservoir. If excessive mineral build-up is found, the cover may need to be removed to facilitate complete cleaning of the humidifier.
Flexible Hose	Inspect for cracks or leaks. It is normal for the hose to become hard and develop a “set”.

Maintenance Notes		
Maintenance Performed	Date	By



Exchanger Gasket Replacement Instructions

WARNING

Disconnect the humidifier power and allow the unit to cool prior to servicing. Drain water level below the level of the exchanger being serviced.

- Loosen the exchanger cover clamp screws with a 7/16" socket wrench until the locknuts can be slid out from the mounting clamps. Repeat this step for all clamps. Remove exchanger.
- Remove the old gasket and adhesive left of the heat exchanger. Make sure this surface is clean, dry, and free of oil, grease or water. Turpentine may be used to clean the surface areas.
- Spray contact adhesive such as 3M product Super 77 on one side of the new gasket and on the exchanger surface where the gasket is to be applied. Allow both surfaces to dry a minimum of one minute or until the surfaces become tacky to assure proper bonding.
- Square one end of the new gasket on one end of the exchanger and set by applying light to moderate pressure to the gasket. Square the other end of the gasket on the other end of the exchanger. It is common for the gasket to appear too long. Now slowly start setting the gasket from the ends towards the middle of the exchanger. A slight compression of the gasket will occur ensuring proper fit on the ends.
- Apply moderate to heavy pressure on the newly installed gasket all the way around ensuring proper fit. A properly installed gasket will lay flat with no raised areas.
- Reinstall the heat exchanger into the humidifier.
- Loosely install all of the exchanger cover clamps.
- Using a 7/16" torque wrench set at 60 inch/pounds tighten all clamp screws.
- In a reverse manner, reconnect all electrical connections. Fill humidifier with water and check for leaks.
- Observe for leaks and tighten slightly if a leak area is found. DO NOT EXCEED 100 inch/pounds.



PURE
Humidifier

Cover Gasket Replacement Instructions

Remove the reservoir cover. While looking at the top of the unit, reference Figure A and B to determine which humidifier tank style you have.

Figure A Installation

Fit the gasket around the entire lip of the tank opening. Cut the gasket 1/8" longer than required, this will ensure proper fit when the cover is clamped back on. Slide the gasket onto lip of tank around the entire perimeter, and seal the ends together with a small amount of silicone.

Figure B Installation

Fit the gasket around the entire lip of the tank opening. Cut the gasket 1/8" longer than required, this will ensure proper fit when the cover is clamped back on. Slide the gasket onto lip of tank around the entire perimeter. Notch only the bottom flap of the gasket (reference Fig. C) in the corners of the tank. Seal the ends together with a small amount of silicone.

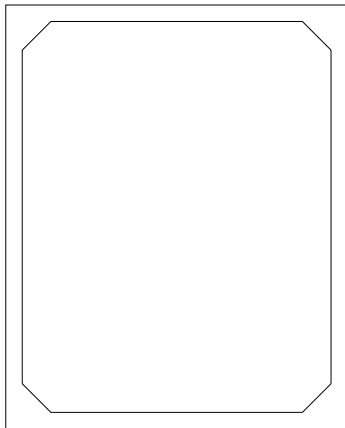

Fig. A
Plan View of Humidifier

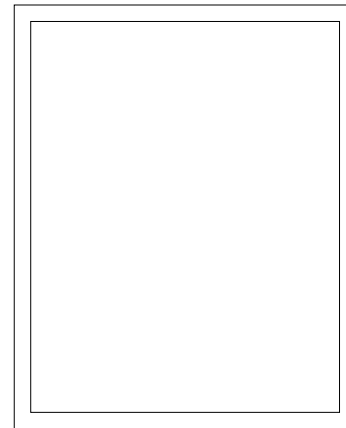
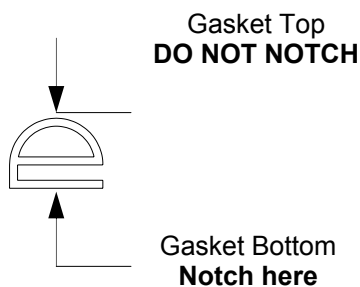
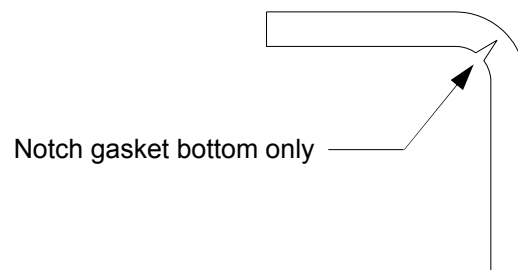

Fig. B
Plan View of Humidifier



Section View of Gasket



Bottom View of Gasket

Fig. C



Trouble Shooting

<u>Problem</u>	<u>Possible Cause</u>	<u>Recommended Action</u>
Humidifier will not heat	Blown main power fuse(s)	Check and replace.
	Control transformer not producing 24 vac control voltage	Check transformer output.
	Safety controls open (airflow proving, high-limit, etc.)	Verify that all safety controls are completing the safety circuit.
	Faulty valve actuator	Check and verify actuator voltage or pneumatic signal. Compare to diagram or nameplate label ratings.
	Faulty humidistat	Verify humidistat electric or pneumatic signal. Compare to diagram or nameplate label ratings.
	Steam trap malfunction	Check and verify that the trap is passing condensate.
	Main steam supply	Check and verify that the main steam supply valves are open and that the steam pressure is at the rated pressure.
Humidifier will not fill	No water pressure	Check water supply.
	Drain valve open	Close drain ball valve.
	Faulty water float valve	Check float valve seat for dirt.
Humidifier does not stop filling or is short cycling	Float valve stuck open	Check float seat for dirt. Adjust float ball arm.
	Drain valve open	Close drain ball valve.



Tool Requirements & Torque List

Recommended Maintenance Tool List

7/16" Wrench
3/4" Wrench
Crescent Wrench
11/32" Nut Driver or Socket
3/8" Nut Driver or Socket
5/32" Allen Head
Flat Head Screwdriver
Wire Stripper
Wire Crimper

Torque List

Cover Bolts	18 inch/pounds MAX
Side Entry Exchanger Bolts	100 inch/pounds MAX
Hose Cuff Screws	35-40 inch/pounds MAX when hot



PURE
Humidifier

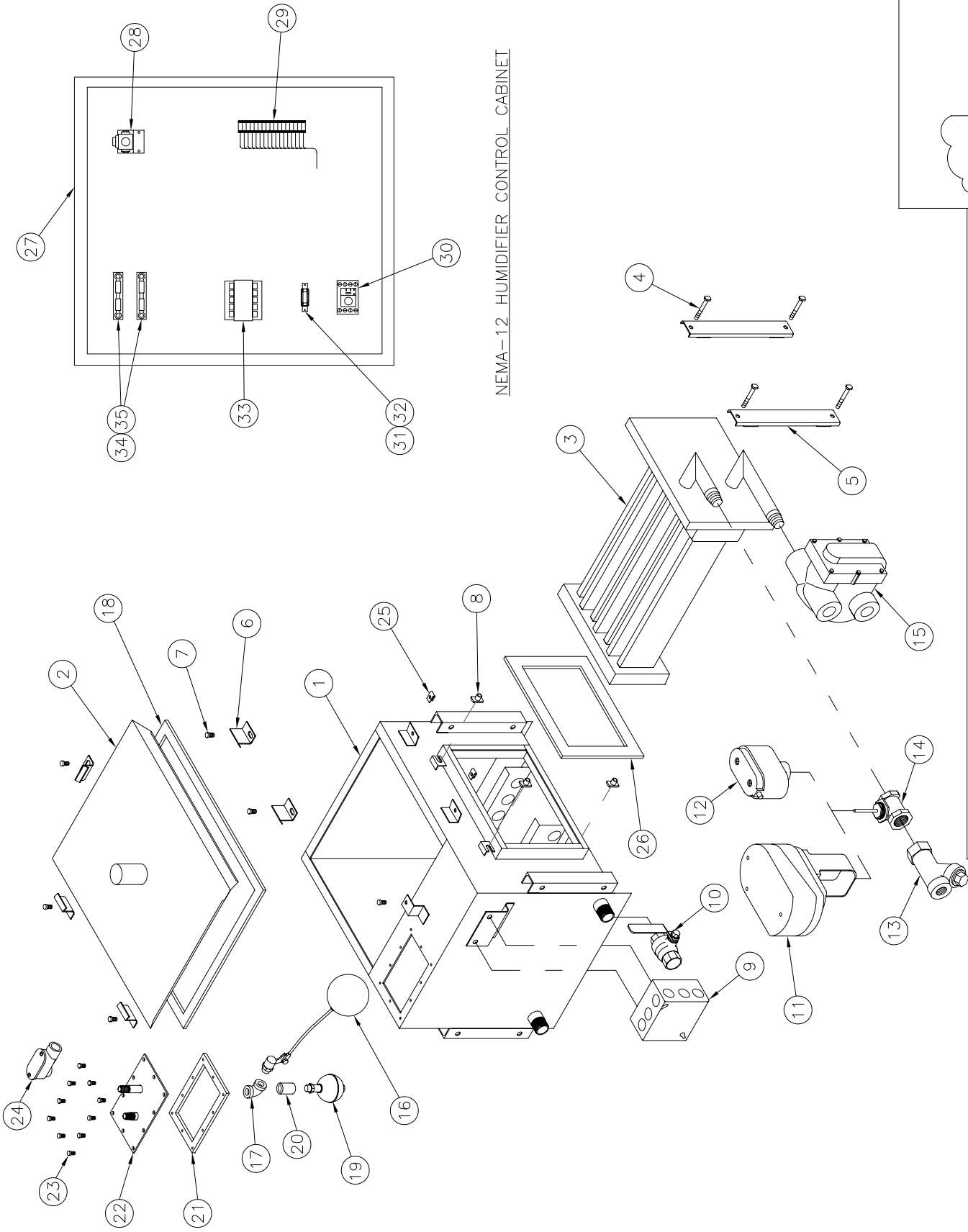

NEMA-12 HUMIDIFIER CONTROL CABINET

Title: SXDDR-1R thru 4R ASSEMBLY PARTS LIST	
Scale: No Scale	Date: April 20, 2009
Drwn: P.R.G.	Dwg No: SXDDR-1R thru 4R EXPLODED ASSEMBLY

**PURE Humidifier Co. "SXDDR" Series
SXDDR-1R thru SXDDR-4R
Parts List & Two Year Recommended Spare Parts**

Item No.	Description	Part No.	Qty Per Unit	Rec. SpareQty
1	SXDDR Reservoir Assembly	A	1	
2	SXDDR Reservoir Cover Assembly	A	1	
3	SXDDR Heat Exchanger Assembly	A	1	
4	U-Clamp Bolts	15526	A	
5	U-Clamp Bar Assembly	99136	A	
6	Cover Clamp	15930	A	
7	Cover Clamp Screws	15522	A	
8	1/4"-20 Weld Nut	15702	A	
9	Electrical Box	15076	1	
10	3/4" Ball Valve 316 SST	09036	1	
11	Electric Valve Actuator	A	1**	
12	Pneumatic Valve Actuator	A	1**	
13	Wye Strainer	A	1	
14	Valve Body	A	1	
15	Float & Thermostatic Trap	15153	1	
16	Float Valve and Ball, 316 SST	A	1	
17	1/4" 90 El. 316 SST	07019	1	
18	Cover Gasket	15520	1	
19	Water Level Control Switch	15048	1	
20	1/4" Coupling 316 SST	07018	1	
21	DDR Float Plate Gasket	05052	1	
22	DDR Float Plate Assembly	99134	1	
23	Float Plate Screws	15523	10	
24	1/2" Junction Box	15079	1	
25	10-24 U-Nut	15524	A	
26	Heat Exchanger Gasket	A	1	
27	Control Enclosure	A	1	
28	Pneumatic 3 Way Valve	09039	1	
29	Terminal Strip	12044	1	
30	On Delay Relay	12022	1	
31	Secondary Fuse Holder	12085	1	
32	Secondary Fuse	12063	1	
33	Step-Down Transformer	12160	A	
34	Primary Fuse Holder	12085	1	
35	Primary Fuse	12209	1	

NOTES/CODES:

A = Part Number and quantity vary with model number.

* Only one style drain valve will be used.

** Only one style valve actuator will be used.

When ordering replacement or spare parts, please have the following information available: Model Number, Serial Number and any options

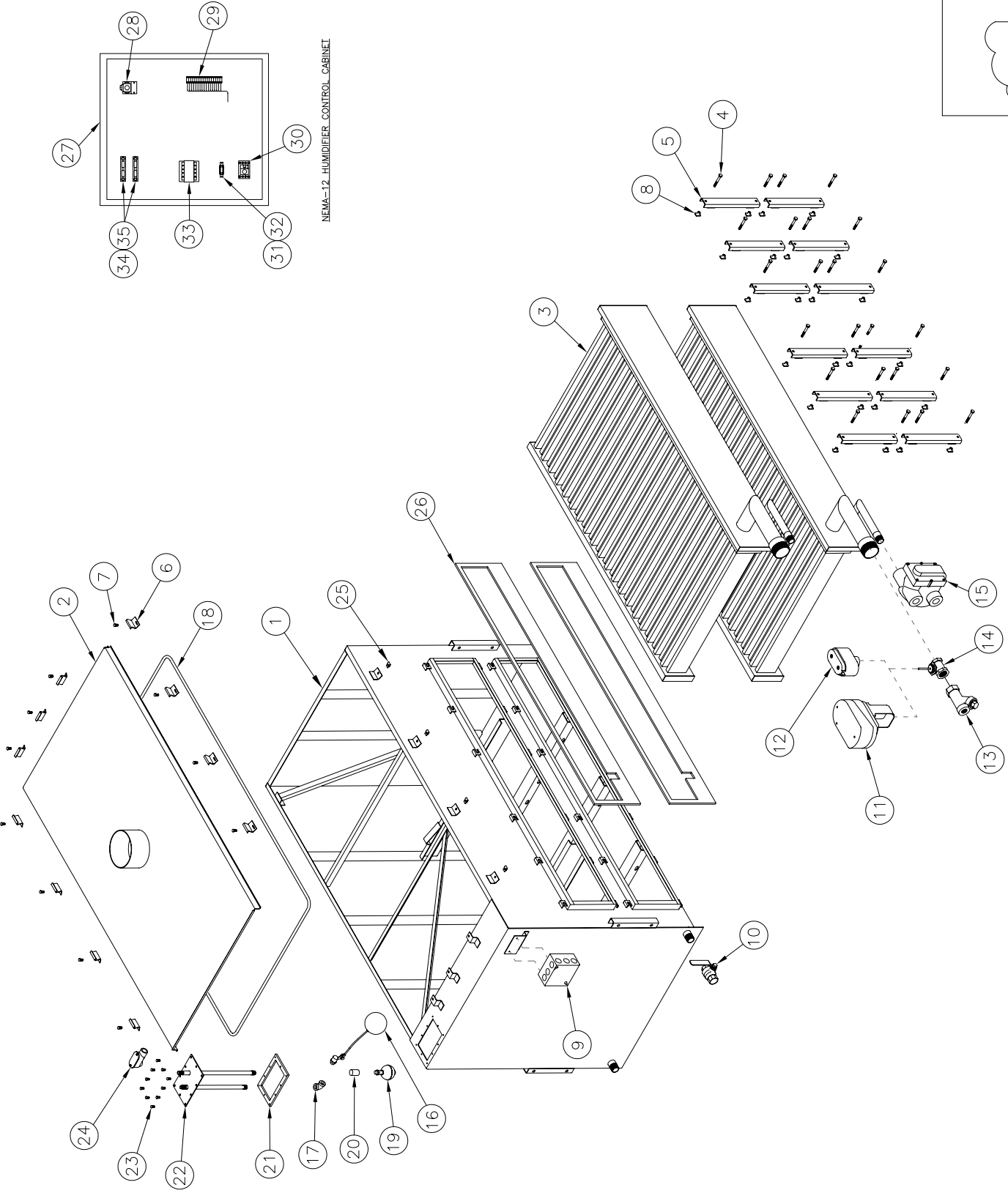

NEMA-12 HUMIDIFIER CONTROL CABINET

Title: SXDDR-8R EXPLODED ASSEMBLY

Scale: No Scale

Date: Mar. 4, 2009

Drwn: P.R.G.

Dwg No: SXDDR-8R EXPLODED ASSEMBLY

**PURE Humidifier Co. "SXDDR" Series
SXDDR-8R
Parts List & Two Year Recommended Spare Parts**

Item No.	Description	Part No.	Qty Per Unit	Rec. SpareQty
1	SXDDR-8R Reservoir Assembly	A	1	
2	SXDDR Reservoir Cover Assembly	A	1	
3	SXDDR-4R Heat Exchanger Assembly	05400	2	
4	U-Clamp Bolts	15526	20	
5	U-Clamp Bar Assembly	99136	10	
6	Cover Clamp	15930	11	
7	Cover Clamp Screws	15522	11	
8	1/4"-20 Weld Nut	15702	20	
9	Electrical Box	15076	1	
10	3/4" Ball Valve 316 SST	09036	1	
11	Electric Valve Actuator	A	2**	
12	Pneumatic Valve Actuator	A	2**	
13	Wye Strainer	A	2	
14	Valve Body	A	2	
15	Float & Thermostatic Trap	15153	2	
16	Float Valve and Ball, 316 SST	09030	1	
17	1/4" 90 El. 316 SST	07019	1	
18	Cover Gasket	15520	1	
19	Water Level Control Switch	15048	1	
20	1/4" Coupling 316 SST	07018	1	
21	DDR Float Plate Gasket	05052	1	
22	DDR Float Plate Assembly	95009	1	
23	Float Plate Screws	15523	10	
24	1/2" Junction Box	15079	1	
25	10-24 U-Nut	15524	11	
26	Heat Exchanger Gasket	05386	1	
27	Control Enclosure	12003	1	
28	Pneumatic 3 Way Valve	09039	1	
29	Terminal Strip	12044	1	
30	On Delay Relay	12022	1	
31	Secondary Fuse Holder	12085	1	
32	Secondary Fuse	12063	1	
33	Step-Down Transformer	12160	A	
34	Primary Fuse Holder	12083	1	
35	Primary Fuse	12209	1	

NOTES/CODES:

A = Part Number and quantity vary with model number.

* Only one style drain valve will be used.

** Only one style valve actuator will be used.

When ordering replacement or spare parts, please have the following information available: Model Number, Serial Number and any options

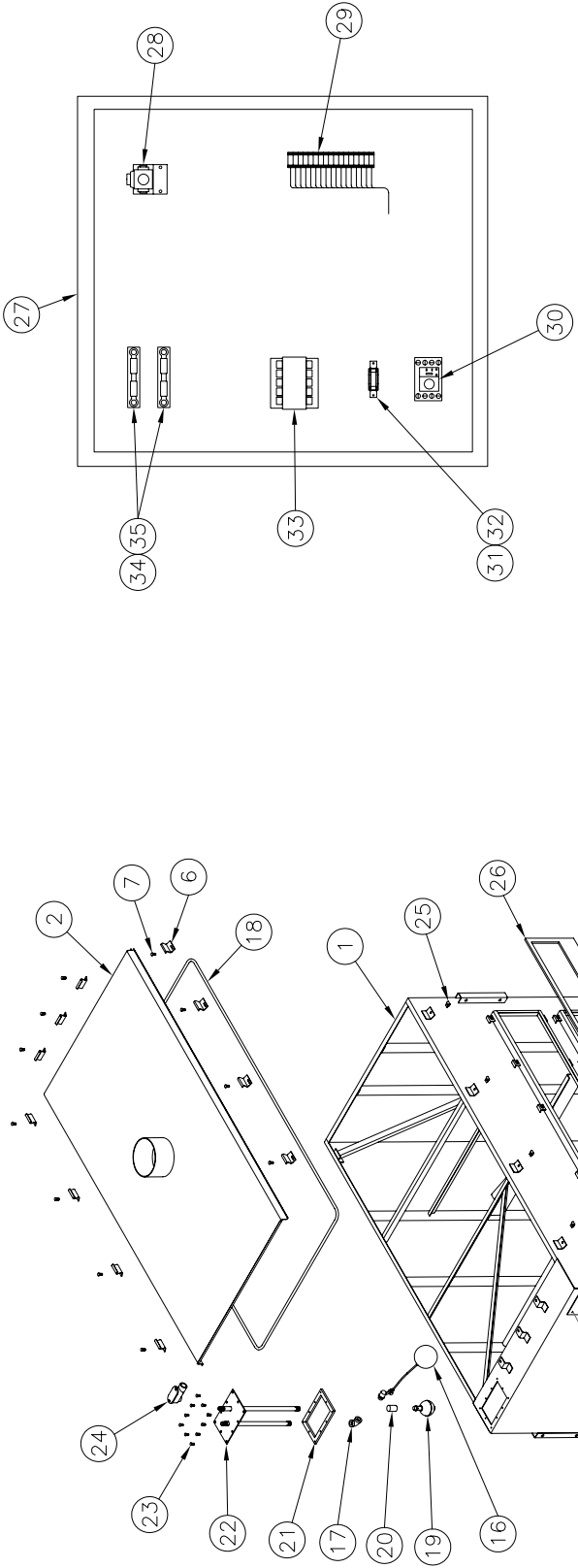

NEMA-12 HUMIDIFIER CONTROL CABINET

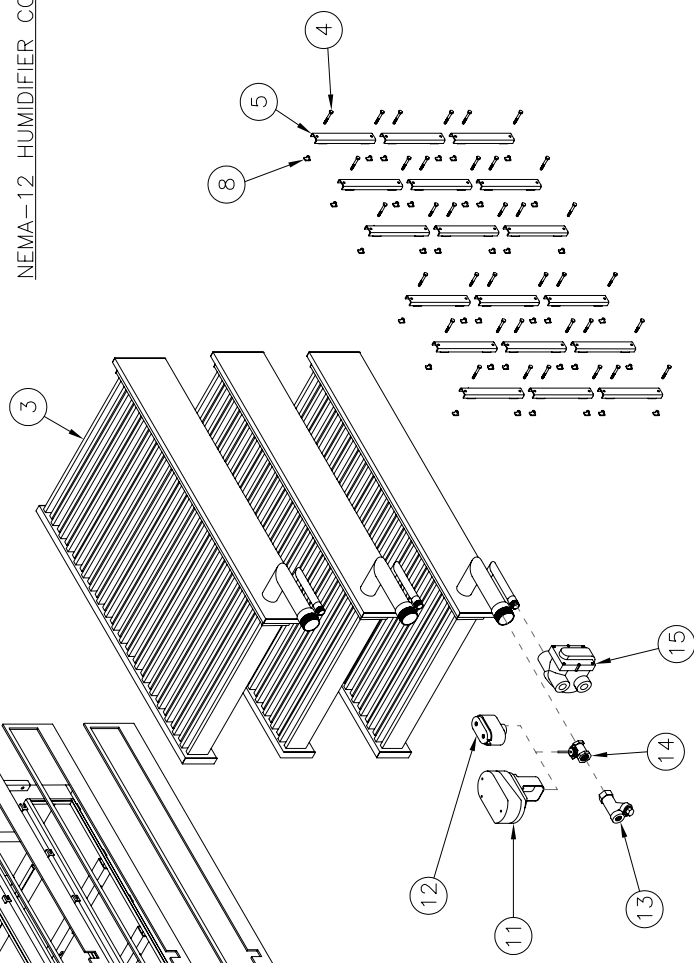

Title: SXDDR-12R EXPLODED ASSEMBLY		Dwg No: SXDDR-12R EXPLODED ASSEMBLY	
Scale: No Scale	Date: Mar. 4, 2009	Drwn: P.R.G.	

**PURE Humidifier Co. "SXDDR" Series
SXDDR-12R
Parts List & Two Year Recommended Spare Parts**

Item No.	Description	Part No.	Qty Per Unit	Rec. SpareQty
1	SXDDR-8R Reservoir Assembly	A	1	
2	SXDDR Reservoir Cover Assembly	A	1	
3	SXDDR-4R Heat Exchanger Assembly	05400	3	
4	U-Clamp Bolts	15526	30	
5	U-Clamp Bar Assembly	99136	15	
6	Cover Clamp	15930	11	
7	Cover Clamp Screws	15522	11	
8	1/4"-20 Weld Nut	15702	30	
9	Electrical Box	15076	1	
10	3/4" Ball Valve 316 SST	09036	1	
11	Electric Valve Actuator	A	3**	
12	Pneumatic Valve Actuator	A	3**	
13	Wye Strainer	A	3	
14	Valve Body	A	3	
15	Float & Thermostatic Trap	15153	3	
16	Float Valve and Ball, 316 SST	09030	1	
17	1/4" 90 El. 316 SST	07019	1	
18	Cover Gasket	15520	1	
19	Water Level Control Switch	15048	1	
20	1/4" Coupling 316 SST	07018	1	
21	DDR Float Plate Gasket	05052	1	
22	DDR Float Plate Assembly	95009	1	
23	Float Plate Screws	15523	10	
24	1/2" Junction Box	15079	1	
25	10-24 U-Nut	15524	11	
26	Heat Exchanger Gasket	05386	1	
27	Control Enclosure	12003	1	
28	Pneumatic 3 Way Valve	09039	1	
29	Terminal Strip	12044	1	
30	On Delay Relay	12022	1	
31	Secondary Fuse Holder	12085	1	
32	Secondary Fuse	12063	1	
33	Step-Down Transformer	12160	A	
34	Primary Fuse Holder	12083	1	
35	Primary Fuse	12209	1	

NOTES/CODES:

A = Part Number and quantity vary with model number.

* Only one style drain valve will be used.

** Only one style valve actuator will be used.

When ordering replacement or spare parts, please have the following information available: Model Number, Serial Number and any options



141 Jonathan Boulevard North
Chaska, MN 55318
Tel: (952) 368-9335 Fax: (952) 368-9338
www.purehumidifier.com